

# Furniture

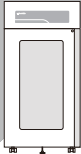

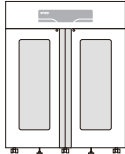

- › Filtering Storage Cabinets
- › Acid/Corrosive Cabinets
- › General Storage Cabinets
- › Gas Cylinder Cabinets

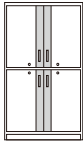
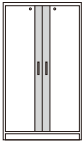

## Filtering Storage Cabinets

	FSC-140	FSC-280
		
Internal volume(L)	604	1317
Width(mm)	930	1868
Height(mm)	1890	1890
Depth(mm)	636	636
Airflow rate (m <sup>3</sup> /min, CMM)	0.67	1.34

## Acid/Corrosive Cabinets

	SC-C1912D4	SC-C1912D2	SC-C1906D2	SC-C1906D1	SC-C0706D1
					
Internal volume(L)	852 (213 x 4 ea)	894 (447 x 2 ea)	426 (213 x 2 ea)	445	115
Width(mm)	1255		655		600
Height(mm)	1900				650
Depth(mm)	555				510

# General Storage Cabinet (Tall - DS-OW / DS-OR)



## Open window type cabinet / Open rack type cabinets

Tempered glass cabinet door allow for easy viewing. (DS-OW)

- Cabinet can be either connected to in-house laboratory exhaust system or extraction module (optional, see page 52) in order to efficiently exhaust the vapor inside of the cabinet.

Multipurpose and stationary storage units. (DS-OR)

### DS-OW

#### Standard accessories

- Trays, Tray dividers
- Name plates, Anchors, Door key

#### Optional accessories

- Extraction module

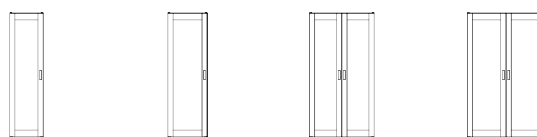
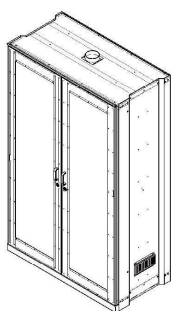

	1800 / 70.9	1800 / 70.9	1800 / 70.9	1800 / 70.9
Exterior height (mm / inch)	1800 / 70.9	1800 / 70.9	1800 / 70.9	1800 / 70.9
Exterior width (mm / inch)	472 / 18.6	556 / 21.9	915 / 36.0	1083 / 42.6
Each drawer width (mm / inch)	418 / 16.5	502 / 19.8	418 / 16.5	502 / 19.8
No. of tray (standard / max.)	6 / 11	6 / 11	12 / 22	12 / 22
Max. load per tray (kg / lbs)	30 / 66.1	30 / 66.1	30 / 66.1	30 / 66.1
No. of name plate	6	6	12	12
Exterior depth (mm / inch)	550 / 21.6	550 / 21.6	550 / 21.6	550 / 21.6
Net weight (kg / lbs)	124 / 273.4	137 / 302.0	146 / 321.9	172 / 379.2
<b>Model</b>	<b>DS-OW-18047N1</b>	<b>DS-OW-18055N1</b>	<b>DS-OW-18091N2</b>	<b>DS-OW-18108N2</b>
<b>Cat. No.</b>	<b>AAAF1050</b>	<b>AAAF1051</b>	<b>AAAF1052</b>	<b>AAAF1053</b>

### DS-OR

#### Standard accessories

- Trays, Tray dividers, Anchors

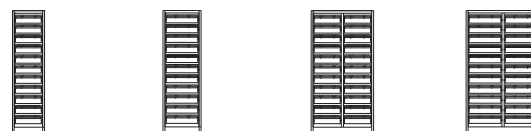
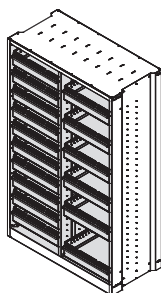

	1800 / 70.9	1800 / 70.9	1800 / 70.9	1800 / 70.9
Exterior height (mm / inch)	1800 / 70.9	1800 / 70.9	1800 / 70.9	1800 / 70.9
Exterior width (mm / inch)	472 / 18.6	556 / 21.9	915 / 36.0	1083 / 42.6
Each drawer width (mm / inch)	418 / 16.5	502 / 19.8	418 / 16.5	502 / 19.8
No. of tray (standard / max.)	11 / 11	11 / 11	22 / 22	22 / 22
Max. load per tray (kg / lbs)	30 / 66.1	30 / 66.1	30 / 66.1	30 / 66.1
Exterior depth (mm / inch)	550 / 21.6	550 / 21.6	550 / 21.6	550 / 21.6
Net weight (kg / lbs)	110 / 242.5	120 / 264.6	215 / 473.9	244 / 537.9
<b>Model</b>	<b>DS-OR-18047N1</b>	<b>DS-OR-18055N1</b>	<b>DS-OR-18091N2</b>	<b>DS-OR-18108N2</b>
<b>Cat. No.</b>	<b>AAAF1090</b>	<b>AAAF1091</b>	<b>AAAF1092</b>	<b>AAAF1093</b>

## Accessories & Options

Cat. No.	Description	Suitable for
AAAF1501	Drawer set (epoxy painted steel, 388x504mm / 15.3x19.8")	DS-OW-
AAAF1502	Drawer set (epoxy painted steel, 472x504mm / 18.6x19.8")	
AAAF1504	Drawer set (stainless steel, 388x504mm / 15.3x19.8")	
AAAF1505	Drawer set (stainless steel, 472x504mm / 18.6x19.8")	
AAAF1507	Drawer set (epoxy painted steel, 388x504mm / 15.3x19.8")	DS-OR-
AAAF1508	Drawer set (epoxy painted steel, 472x504mm / 18.6x19.8")	
AAAF1509	Drawer set (stainless steel, 388x504mm / 15.3x19.8")	
AAAF1510	Drawer set (stainless steel, 472x504mm / 18.6x19.8")	
CBN0018	Tray divider (370mm / 14.6" width)	DS-OW-
CBN0019	Tray divider (450mm / 17.7" width)	
CBN0018	Tray divider (370mm / 14.6" width)	DS-OR-
CBN0019	Tray divider (450mm / 17.7" width)	
AAAF1523	Name plate B1 (320x115mm / 12.6x4.5")	DS-OW-

Constructed progressively strong, and for storage of gas cylinders inside of buildings.

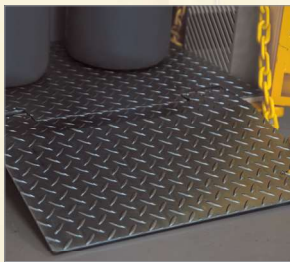

### Large interior

Wide fold down ramp, safe and easy to maneuver gas cylinders in and out of the cabinet, easy to install gas fittings and pipes.



### Spark-proof plastic chains

Convenient for securing gas cylinders in place, prevents gas cylinders from getting scratched.

Front and both side vent slits vents the cabinet effectively disperses the gas leak out of the cabinet in case there is damage to one of the gas cylinders.

## DS-GC

### Standard accessories

- Door key

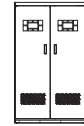
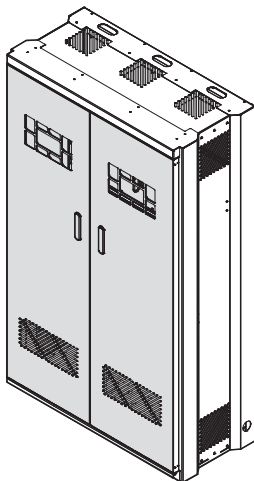

Exterior height (mm / inch)	1800 / 70.9	1800 / 70.9
Exterior width (mm / inch)	740 / 29.1	1070 / 42.1
Max. storage capacity of $\varnothing$ 230mm gas cylinder	2	3
Exterior depth (mm / inch)	550 / 21.6	550 / 21.6
Net weight (kg / lbs)	107 / 235.9	140 / 308.6
<b>Model</b>	<b>DS-GC-18074N2</b>	<b>DS-GC-18107N2</b>
<b>Cat. No.</b>	<b>AAAF1070</b>	<b>AAAF1071</b>