



LRE 1400

A STABLE RUNNING UNIT THAT OFFERS GREAT LEVEL OF FLEXIBILITY

The LRE 1400 features air forced cooling for high temperature stability and quick temperature recovery after door openings.



AIR FORCED COOLING



FILTERLESS CONSTRUCTION

EXTRA SECURITY

The LRE 1400 has multiple safety features as standard. The range comes with a built-in lock to restrict access to the stored samples. Besides the physical security, the LRE 1400 comes with electronic safety features. The temperature display has a high/low temperature audio and visual alarms along with a door open alarm. The controller records the minimum and maximum temperature which ensures that your samples have never gone out of the set temperature range.

MONOBLOCK TECHNOLOGY

With the monoblock technology you get several advantages, such as more storage space per square meter of floor space, because the evaporator is not taking up space from the storage area of the unit.

With the removal of the evaporator from the inside of the unit, you also get a much smaller impact on the air temperature during automatic defrost.

EASY MAINTENANCE

Filterless constructions prevents problems due to dust in the filter. The dust will block the air flow through the condenser, which reduces the ability to effectively dissipate heat.

The air that bypasses the clogged air filter will carry dirt into the condenser, which will increase the energy used in the compressor and generate additional heat for the ambient environment.

MAIN DIMENSION FOR LRE 1400

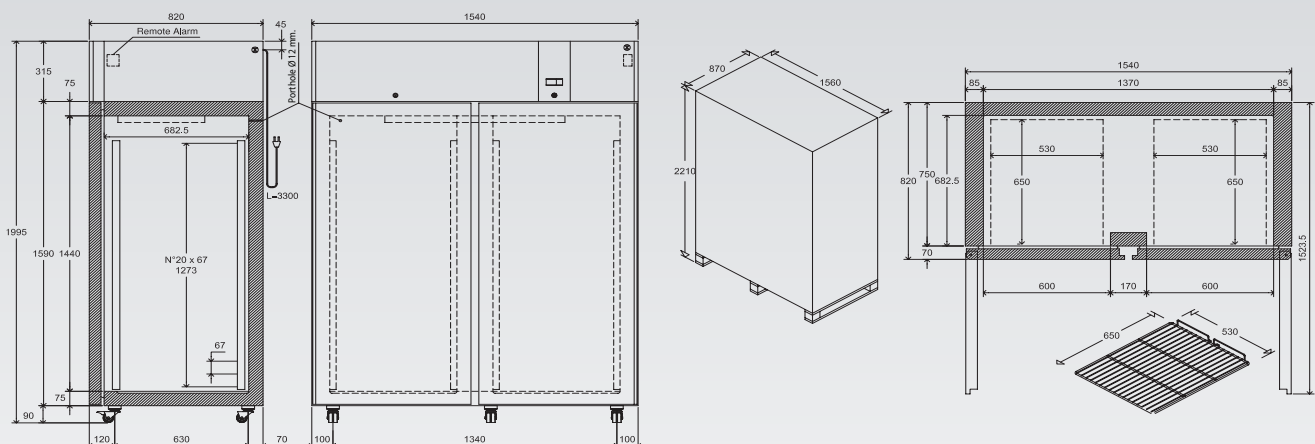



The Carel controller features, among others, visual and acoustic alarm, high/low temperature alarm and open door alarm.



Lock is a standard feature in our LRE 1400. Two key locks with keys for each chamber, for optimal security of both chambers.

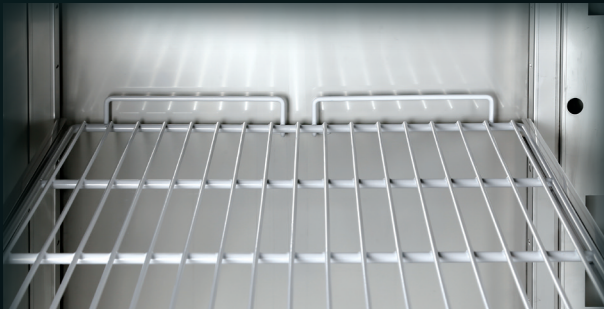

LRE 1400 feature coated wire shelves with a maximum load up to 45 kg

OPTIONAL ACCESSORIES

- Wire shelf plastic coated
- Wire shelf stainless steel
- Temperature chart recorder
- GSM alarm module 3G/4G
- Anti freeze thermostat
- Door reverse kit
- Voltage stabilizer
- Voltage converter

MAIN SPECIFICATIONS

Item code	DAI 7015
Temperature range (°C)	+1 / +10
Max. ambient temperature (°C)	43
Capacity (L)	1345
Exterior dimensions WxDxH (mm)	1540x820x1995
Interior dimensions WxDxH (mm)	1370x682x1440
Weight (KG)	197
Insulation (mm)	85
Cooling technology	air forced
Controller model / probe type	Carel / NTC

POWER

Power supply (V)	230*
Frequency (Hz)	50
Power consumption (kWh/24H)	2,8
AMP (A)	2,2
Power (Watt)	320
Horse power (HP)	1/3

ALARM FUNCTIONS

Alarm display as text - not codes	no
Visual / acoustic alarm	yes / yes
Power failure alarm	no
Adjustable high / low temperature alarm	yes / yes
Open door alarm	yes
Probe failure alarm	yes
Low battery alarm	no
Compressor failure alarm	no
Battery backup for alarms (approx. hrs.)	no

DATA LOGGING & EXTERNAL CONNECTION

Voltage free contact for remote alarm (e.g. GSM module)	yes
Electronic data logger	no
RS 485 port	no
USB port for software update & data download	no
Temperature chart recorder	optional

DISPLAY FEATURES

Display type	LED display touch buttons
Number of optional reference probes	no
Password protection for turning unit on / off	no
Temperature graph on display	no

OTHER FEATURES

Automatic defrost	no
Vacuum release port	no
Access port for external probe etc. (int. diameter mm)	12
Light	no
Lock with key	yes
Castors (total pcs) / castors with brake (pcs)	4 / 2
Feet (pcs) / levelling feet (pcs)	no
Sub lids or inner doors (pcs)	no
Reversible door(s)	yes
Fixed shelves (pcs) / adjustable shelves (pcs)	0 / 6
Max no. shelves (pcs) / recommended max no. shelves (pcs)	20 / 10
Max load per shelf (kg)	45

REFRIGERATION & CABINET

Number of compressors	1
Refrigerant	R290
Interior cabinet material	stainless steel
Exterior cabinet material	coated steel
Colour (exterior cabinet)	white
Foam type	polyurethane
VIP vacuum insulated panels	no

SHIPPING

Shipping weight (KG)	231
Shipping dimensions WxDxH (cm)	156x87x221
Shipping volume (m ³)	3

*110V/60Hz available as option

Arctiko A/S

Oddesundvej 39 · DK-6715 Esbjerg N · Phone: +45 7020 0328
info@arctiko.com ■ arctiko.com



Intertek

Intertek